

INVERNO

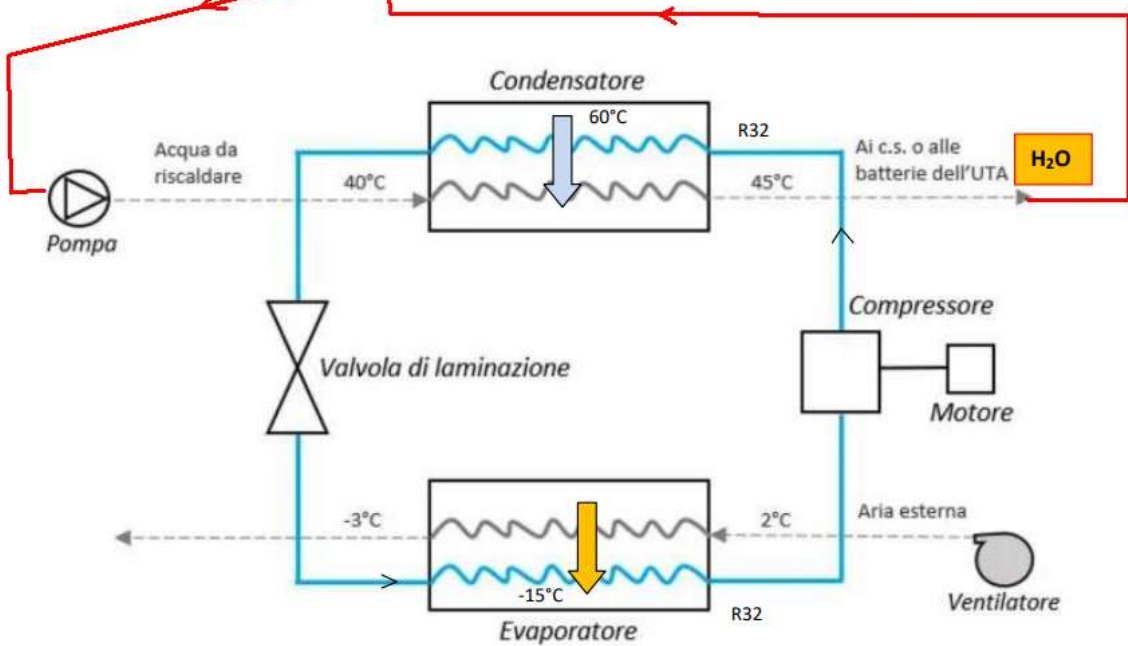

Regime invernale: M – P – Q

ESTATE

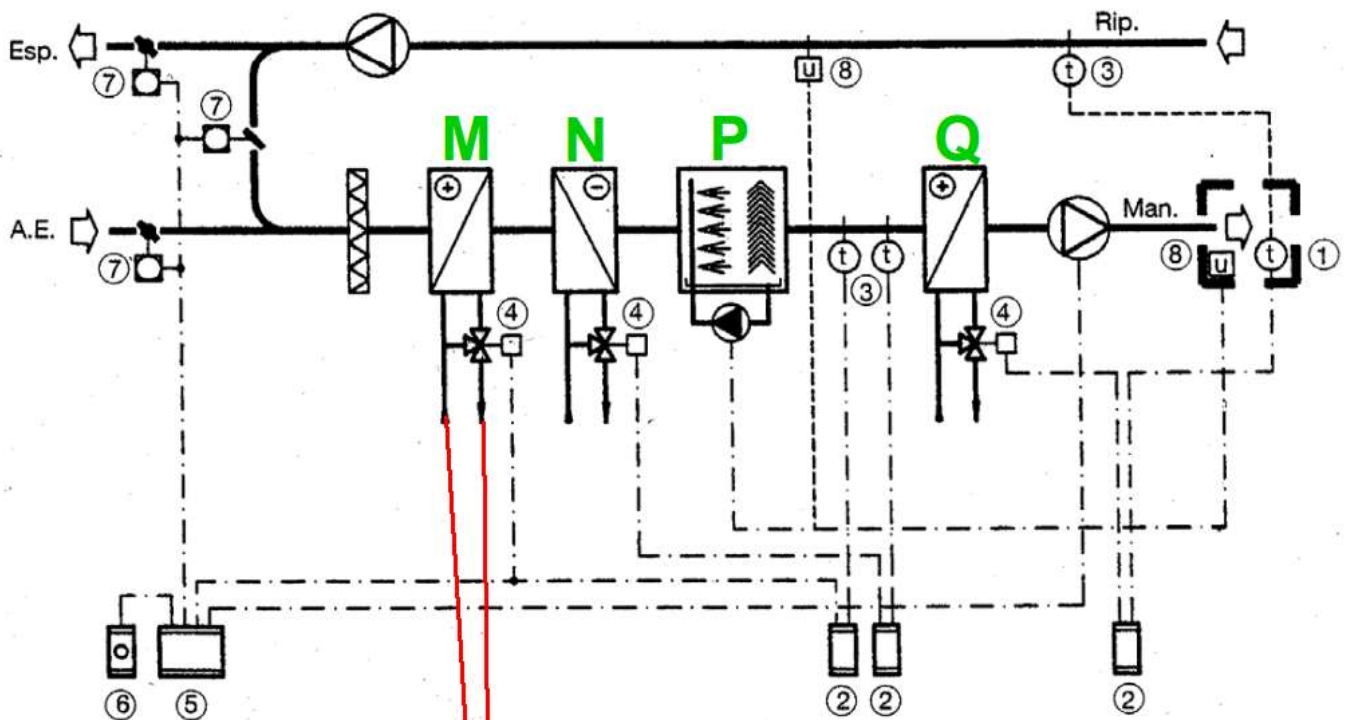
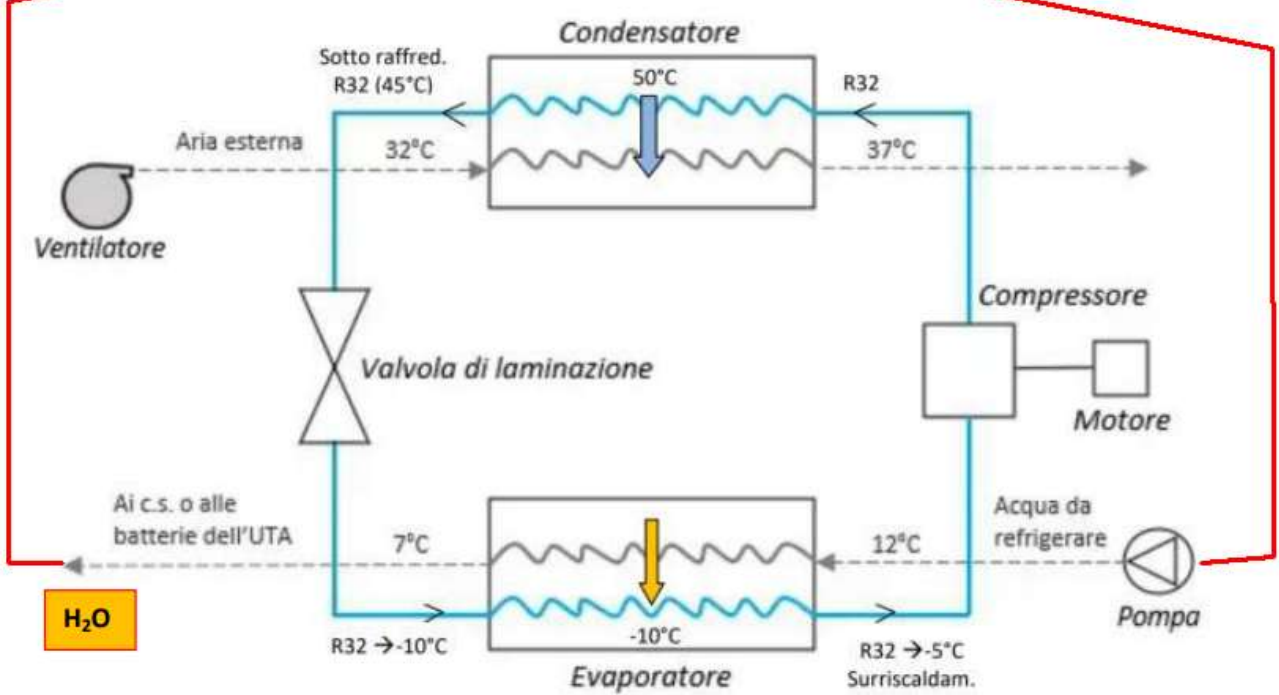
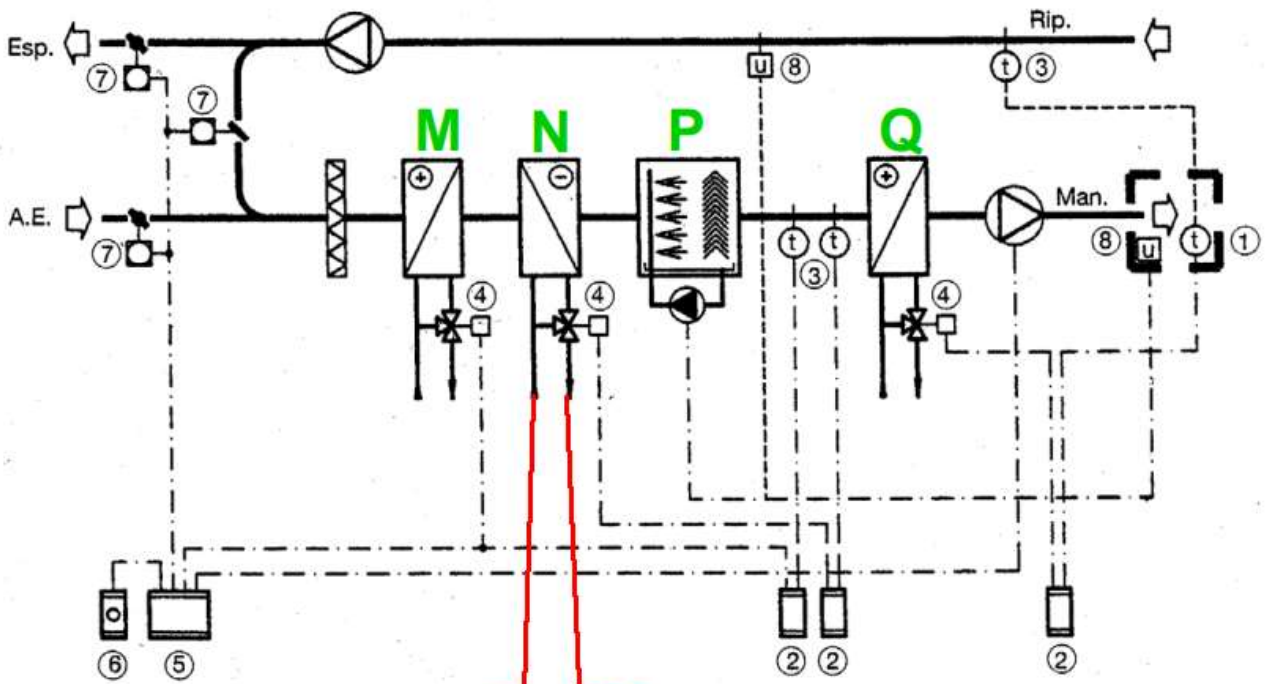

Regime estivo: N - Q